

ILX450 Series LED Industrial Lighting

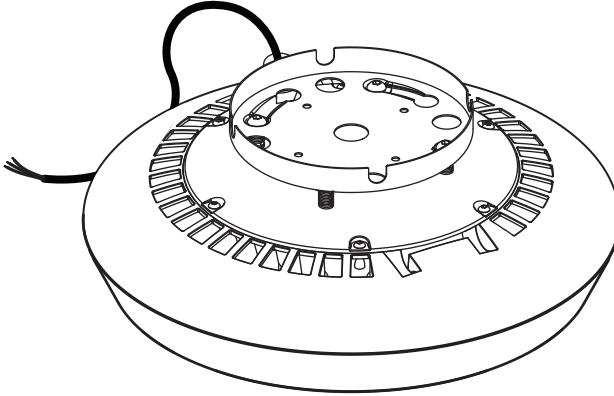

INSTALLATION GUIDE SST - Spring Loaded Snap & Turn Surface Mounting



ITEMS INCLUDED FOR INSTALLATION

- One ILX450 LED Industrial Light with SST pre-mount
- One (SST) Spring Loaded Snap & Turn Surface Mounting Bracket
- Four sets of anchoring kit for concrete surfaces
- One standard wire fitting for junction-box knockout hole
- Installation manual

FEATURES AND APPLICATIONS

- L70 Rating @ Ta 25°C Over 160,000 hour rated life
- Low / Mid / High Bay applications
- Available in Type II, V Round, V Square
- 10-Year Limited Warranty
- IP68 (Water / Dust / Vapor Proof) rated fixture
- Indoor / outdoor applications
- Low profile industrial grade design
- Easy to install with versatile mounting system
- Food Processing Plants
- Manufacturing Plants
- Warehouses
- Parking Structures
- Canopy Lighting
- Sports Arenas
- Airplane Hangars
- Refineries & Petrochemical Plants

ILX450 Series LED Industrial Lighting



INSTALLATION GUIDE SST - Spring Loaded Snap & Turn Surface Mounting

External Dimensions

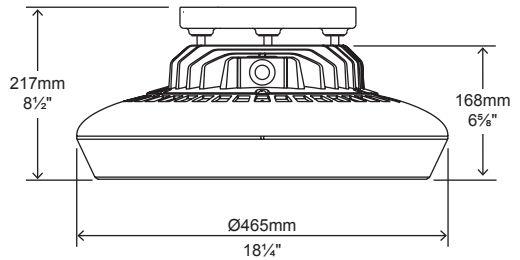
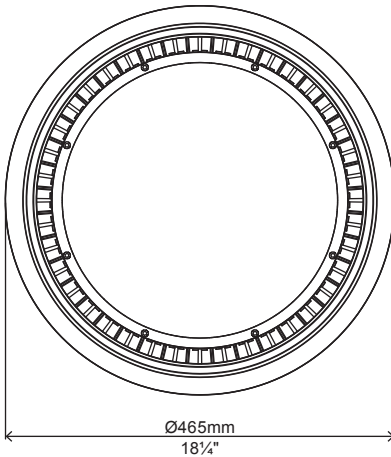

Packaging Information

Case Quantity	Dimensions (LxWxH)	Weight
1	50 x 50 x 28 cm 19 5/8 x 19 5/8 x 11 in	16.5 kg 36.3 lbs

WARNING

RISK OF ELECTRIC SHOCK

- Installation must be done by a certified electrician and / or qualified personnel.
- Make sure to turn OFF the main power from the circuit breaker or fuse box before installing, servicing or inspecting this fixture.
- Make sure all grounding wires are connected correctly.

RISK OF FIRE

- Ensure that all line voltage wire is intended for specified product wattage.
- Use UL and / or CE approved wires for all input connections, minimum size required 18 AWG (0.82mm²)
- Do not use this product in environments where the temperatures could exceed **65°C (149°F)**

* BEFORE YOU INSTALL this fixture please read these instructions carefully and completely

ILX450 Series LED Industrial Lighting



INSTALLATION GUIDE SST - Spring Loaded Snap & Turn Surface Mounting

1.

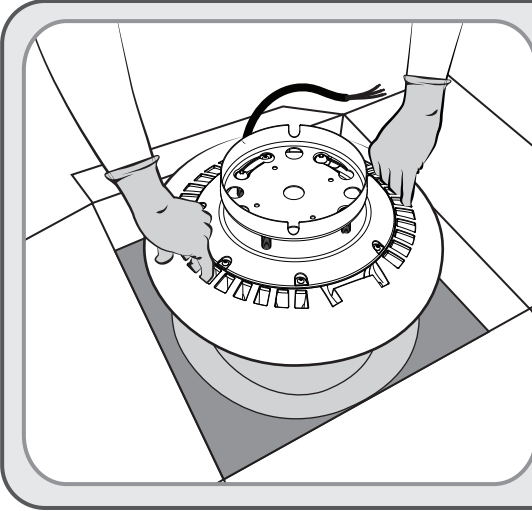

- Handle fixture with care while unpacking the unit from its packaging and carefully examine the unit for defects before installing. Report any damage and save all packing materials if any part is damaged during transport. We recommend wearing work gloves when installing this fixture to prevent dirt and oil from coming into contact with the fixture.

2.

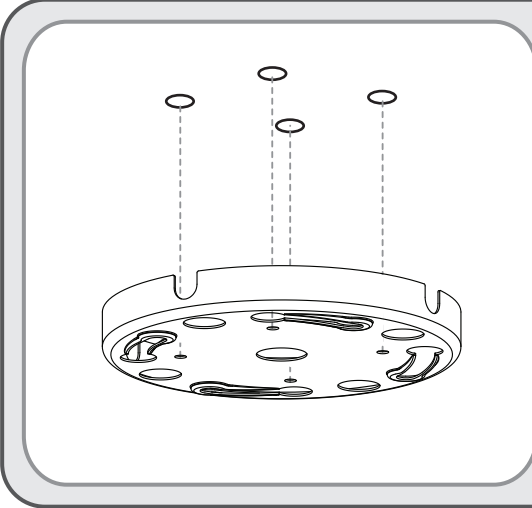

- Use the SST mounting bracket as a template to mark the screw holes location onto the intended surface.

ILX450 Series LED Industrial Lighting



INSTALLATION GUIDE SST - Spring Loaded Snap & Turn Surface Mounting

3.

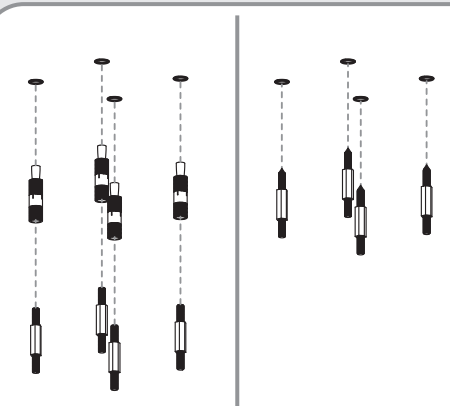

Concrete | **Wood**

- For concrete surfaces use a $\text{Ø}5/16''$ (8.0mm) drill bit and drill holes 1-1/4" (30mm) deep at the marked locations. (Make sure that all dimensions are precise)
- Hammer all four concrete anchors into the four drilled holes until they are flush with the surface.
- Tighten all four hexagon spacers firmly into the concrete anchors.
- For wooden surfaces use a $\text{Ø}1/8''$ (5.0mm) drill bit and drill holes 1-1/4" (30mm) deep at the marked locations.
- Tighten all four hexagon spacers firmly into the drilled holes.

4.

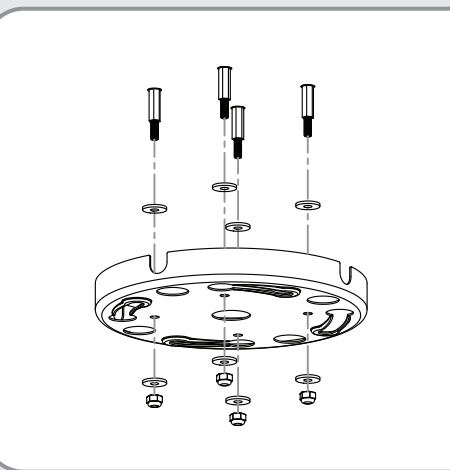

- Align and tighten the SST (Spring Loaded Snap and Turn Surface Mounting Bracket) onto the hexagon spacers using the hexagon nuts and washers provided in the kit.

ILX450 Series LED Industrial Lighting



INSTALLATION GUIDE SST - Spring Loaded Snap & Turn Surface Mounting

5.

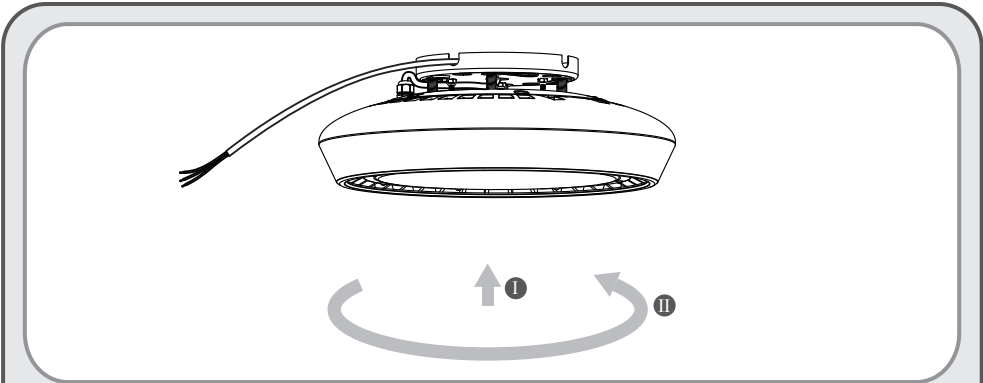

- Align the 4 spring loaded bolts located on top of the fixture with the 4 larger holes along the semicircular slotted holes.
- Push the fixture firmly upwards until the springs are compressed and the bolt heads have gone through the slotted holes of the SST mounting bracket. Then turn the complete fixture clockwise until the bolt heads have fallen into the recessed groove of the mounting bracket.
- Make sure that the fixture cannot be turned counter clockwise and is firmly in place.
- Insert the fixture input AC cable wire through the center hole of the SST mounting bracket and pass it through the side exiting hole of the mounting bracket.

ILX450 Series LED Industrial Lighting



INSTALLATION GUIDE SST - Spring Loaded Snap & Turn Surface Mounting

6.

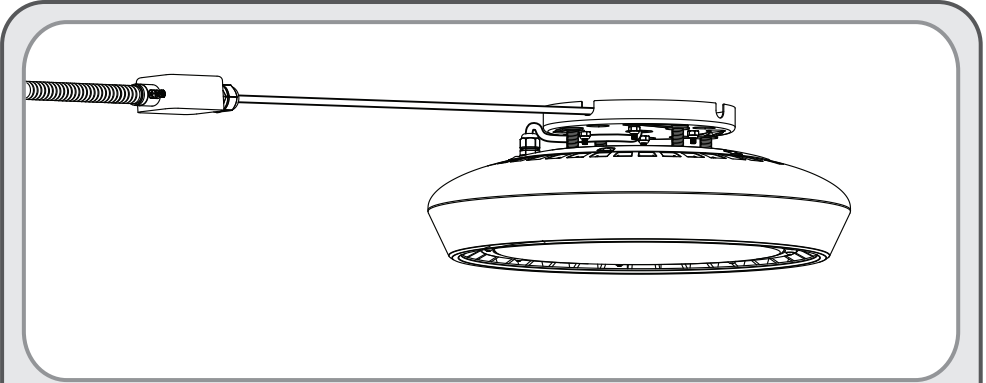

Warning!

- Before connecting any AC input electrical wiring to the electric grid make sure to turn OFF power to all appropriate circuit at the breaker box.
- Carefully unscrew and remove the junction-box cover.
- Insert AC line input wires through the knock out hole. Install proper electrical fittings at the knockout hole for wire protection, provided with the installation kit. Nominal strip length with 5/8" (15 mm) long.
- Connect the AC input line (L) wire to the corresponding marked AC line (**L-BLACK**) wire with a wire nut. Connect the AC input neutral (N) wire to the corresponding marked AC neutral (**N-WHITE**) wire with a wire nut. Ground fixture by connecting the input ground wire (⊕) to the corresponding marked ground wire (⊕ - **GREEN**) on the quick connect terminal block.
- Firmly tighten junction-box cover before testing the fixture.

ILX450 Series LED Industrial Lighting



INSTALLATION GUIDE SST - Spring Loaded Snap & Turn Surface Mounting

Wiring Information

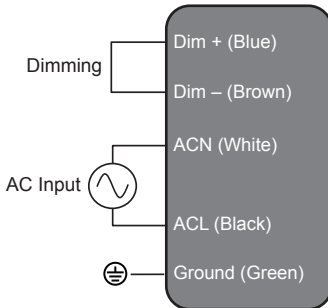

- NOTE:**
- Ensure that all line voltage wire is intended for specified product wattage.
 - Use UL and / or CE approved wires for all input connections, minimum size required 18 AWG (0.82mm²)
 - Refer to the specific dimmer installation manual for exact wiring instructions.

WARNING

RISK OF ELECTRIC SHOCK

- Installation must be done by a certified electrician and / or qualified personnel.
- Make sure to turn OFF the main power from the circuit breaker or fuse box before installing, servicing or inspecting this fixture.
- Make sure all grounding wires are connected correctly.

RISK OF FIRE

- Ensure that all line voltage wire is intended for specified product wattage.
- Use UL and / or CE approved wires for all input connections, minimum size required 18 AWG (0.82mm²)
- Do not use this product in environments where the temperatures could exceed **65°C (149°F)**

NOTE

- While the fixture is **ON**, do not cover the front surface of the light fixture or place it on any flat surfaces that would cover the front air ventilation holes for more than 30 minutes. This will prevent the fixture from properly cooling via air convection and can cause the fixture to overheat & fail.

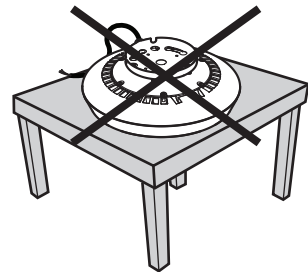

* BEFORE YOU INSTALL this fixture please read these instructions carefully and completely

ILX450 Series LED Industrial Lighting



INSTALLATION GUIDE SST - Spring Loaded Snap & Turn Hanging System

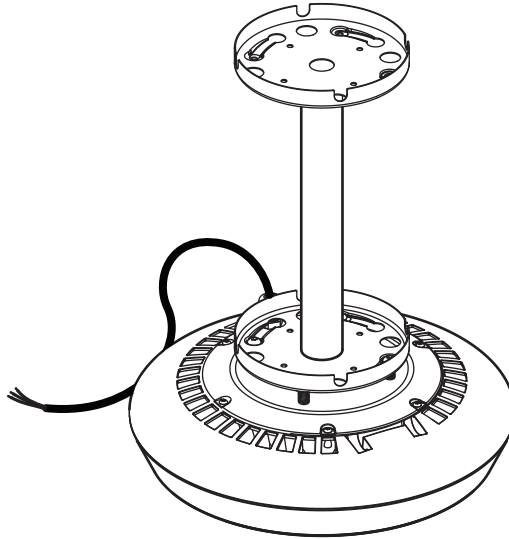

ITEMS INCLUDED FOR INSTALLATION

- One ILX450 LED Industrial Light with SST pre-mount
- One (SST) Spring Loaded Snap & Turn Pipe Hanging Bracket
- Four sets of anchoring kit for concrete surfaces
- One standard wire fitting for junction-box knockout hole
- Installation manual

FEATURES AND APPLICATIONS

- L70 Rating @ Ta 25°C Over 160,000 hour rated life
- Low / Mid / High Bay applications
- Available in Type II, V Round, V Square
- 10-Year Warranty
- IP68 (Water / Dust / Vapor Proof) rated fixture
- Indoor / outdoor applications
- Low profile industrial grade design
- Easy to install with versatile mounting system
- Food Processing Plants
- Manufacturing Plants
- Warehouses
- Parking Structures
- Canopy Lighting
- Sports Arenas
- Airplane Hangars
- Refineries & Petrochemical Plants

ILX450 Series LED Industrial Lighting



INSTALLATION GUIDE SST - Spring Loaded Snap & Turn Hanging System

External Dimensions

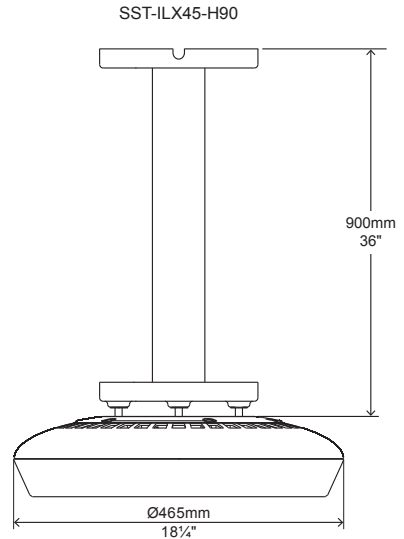
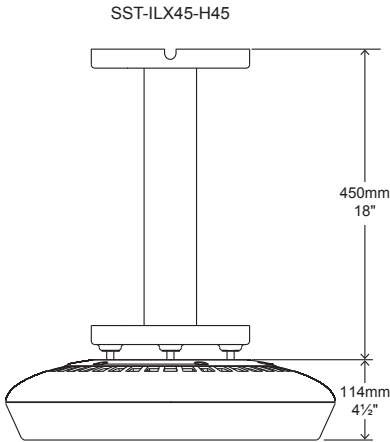

Packaging Information

Case Quantity	Dimensions (LxWxH)	Weight
1	50 x 50 x 22.5 cm 19 3/8 x 19 3/8 x 8 7/8 in	12.5 kg 27.5 lbs

WARNING

RISK OF ELECTRIC SHOCK

- Installation must be done by a certified electrician and / or qualified personnel.
- Make sure to turn OFF the main power from the circuit breaker or fuse box before installing, servicing or inspecting this fixture.
- Make sure all grounding wires are connected correctly.

RISK OF FIRE

- Ensure that all line voltage wire is intended for specified product wattage.
- Use UL and / or CE approved wires for all input connections, minimum size required 18 AWG (0.82mm²)
- Do not use this product in environments where the temperatures could exceed **50°C (122°F)**

* BEFORE YOU INSTALL this fixture please read these instructions carefully and completely

ILX450 Series LED Industrial Lighting



INSTALLATION GUIDE SST - Spring Loaded Snap & Turn Hanging System

1.

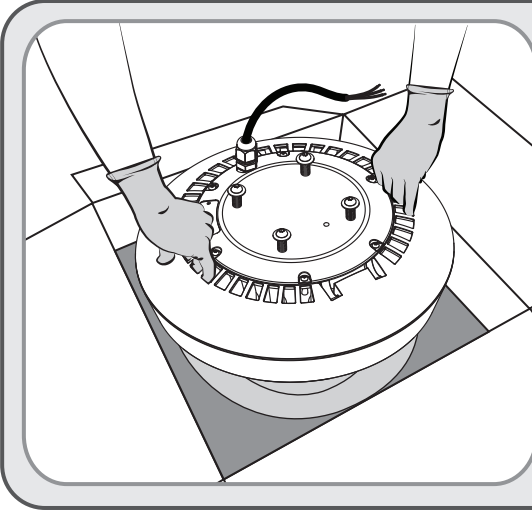

- Handle fixture with care while unpacking the unit from its packaging and carefully examine the unit for defects before installing. Report any damage and save all packing materials if any part is damaged during transport. We recommend wearing work gloves when installing this fixture to prevent dirt and oil from coming into contact with the fixture.

2.

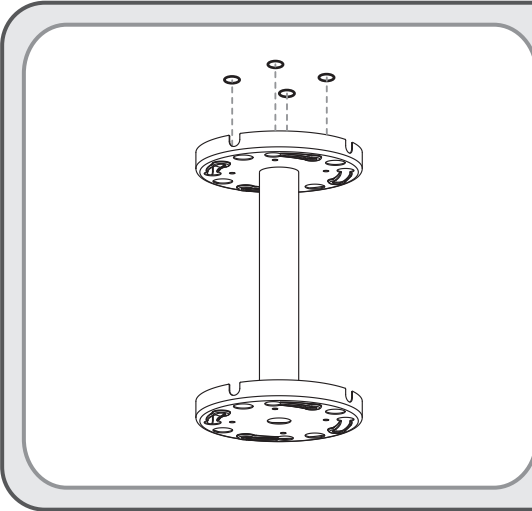

- Use the SST mounting bracket as a template to mark the screw holes location onto the intended surface.

ILX450 Series LED Industrial Lighting



INSTALLATION GUIDE SST - Spring Loaded Snap & Turn Hanging System

3.

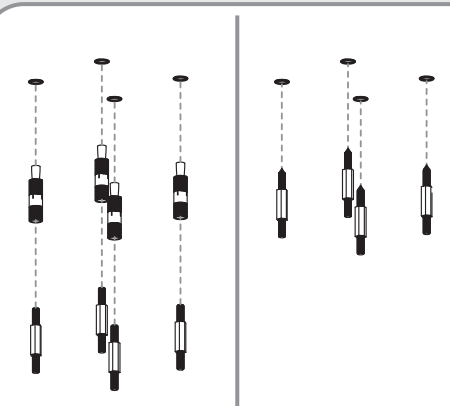

Concrete | **Wood**

- For concrete surfaces use a $\text{Ø}5/16''$ (8.0mm) drill bit and drill holes 1-1/4" (30mm) deep at the marked locations. (Make sure that all dimensions are precise)
- Hammer all four concrete anchors into the four drilled holes until they are flush with the surface.
- Tighten all four hexagon spacers firmly into the concrete anchors.
- For wooden surfaces use a $\text{Ø}1/8''$ (5.0mm) drill bit and drill holes 1-1/4" (30mm) deep at the marked locations.
- Tighten all four hexagon spacers firmly into the drilled holes.

4.

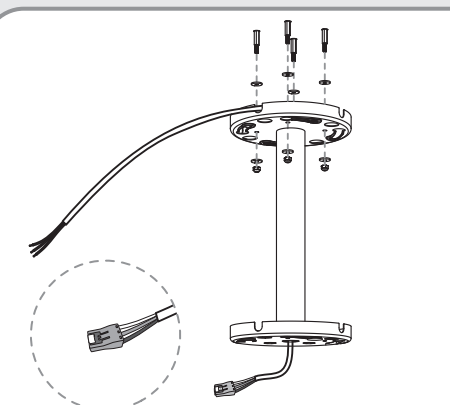

Quick Connect

- Insert the AC input extension cable wire from the top of the mounting bracket down through the pipe coming out at the bottom SST mounting bracket.
- Align and tighten the SST Pipe Hanging Bracket onto the hexagon spacers using the hexagon nuts and washers provided in the kit.
- Make sure that the AC input cable wire at the top passes through the side exiting hole of the top SST mounting bracket.

ILX450 Series LED Industrial Lighting



INSTALLATION GUIDE SST - Spring Loaded Snap & Turn Hanging System

5.

Quick Connect

- Align the 4 spring loaded bolts located on top of the fixture with the 4 larger holes along the semicircular slotted holes.
- Push the fixture firmly upwards until the springs are compressed and the bolt heads have gone through the slotted holes of the SST mounting bracket. Then turn the complete fixture clockwise until the bolt heads have fallen into the recessed groove of the mounting bracket.
- Make sure that the fixture cannot be turned counter clockwise and is firmly in place.
- Connect the fixture to the AC input extension cable via the quick connector provided in the fixture kit.

ILX450 Series LED Industrial Lighting



INSTALLATION GUIDE SST - Spring Loaded Snap & Turn Hanging System

6.

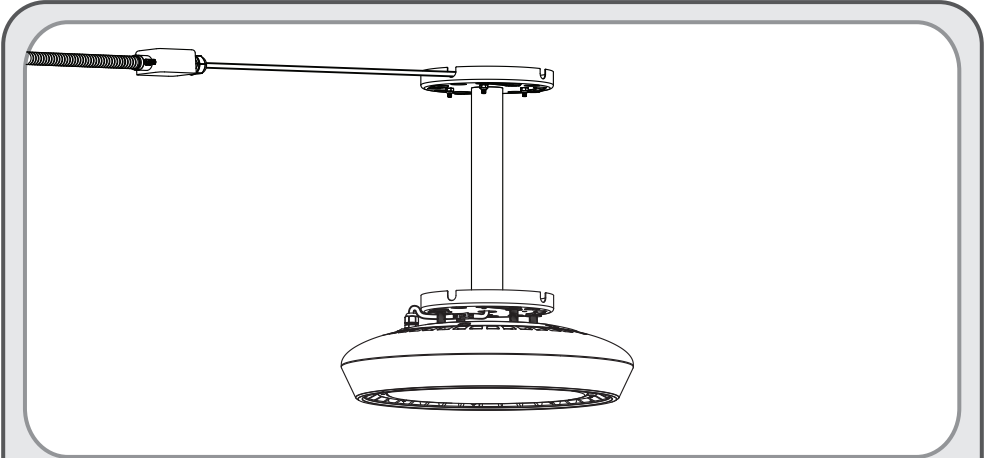

Warning!

- Before connecting any AC input electrical wiring to the electric grid make sure to turn OFF power to all appropriate circuit at the breaker box.
- Carefully unscrew and remove the junction-box cover.
- Insert AC line input wires through the knock out hole. Install proper electrical fittings at the knockout hole for wire protection, provided with the installation kit. Nominal strip length with 5/8" (15 mm) long.
- Connect the AC input line (L) wire to the corresponding marked AC line (**L-BLACK**) wire with a wire nut. Connect the AC input neutral (N) wire to the corresponding marked AC neutral (**N-WHITE**) wire with a wire nut. Ground fixture by connecting the input ground wire (⊕) to the corresponding marked ground wire (⊕ - **GREEN**) on the quick connect terminal block.
- Firmly tighten junction-box cover before testing the fixture.

ILX450 Series LED Industrial Lighting



INSTALLATION GUIDE SST - Spring Loaded Snap & Turn Hanging System

Wiring Information

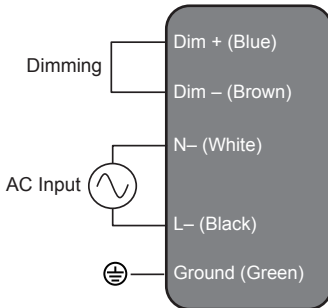

- NOTE:**
- Ensure that all line voltage wire is intended for specified product wattage.
 - Use UL and / or CE approved wires for all input connections, minimum size required 18 AWG (0.82mm²)
 - Refer to the specific dimmer installation manual for exact wiring instructions.

WARNING

RISK OF ELECTRIC SHOCK

- Installation must be done by a certified electrician and / or qualified personnel.
- Make sure to turn OFF the main power from the circuit breaker or fuse box before installing, servicing or inspecting this fixture.
- Make sure all grounding wires are connected correctly.

RISK OF FIRE

- Ensure that all line voltage wire is intended for specified product wattage.
- Use UL and / or CE approved wires for all input connections, minimum size required 18 AWG (0.82mm²)
- Do not use this product in environments where the temperatures could exceed **65°C (149°F)**

NOTE

- While the fixture is **ON**, do not cover the front surface of the light fixture or place it on any flat surfaces that would cover the front air ventilation holes for more than 30 minutes. This will prevent the fixture from properly cooling via air convection and can cause the fixture to overheat & fail.

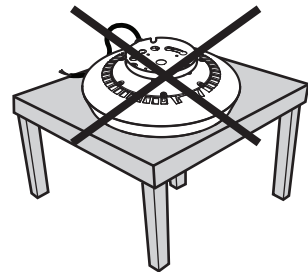

* BEFORE YOU INSTALL this fixture please read these instructions carefully and completely